

---

## Design of Automatic Doors Using Body Temperature Sensors

**Tri Isra Janwardi**

Electrical Engineering, Efarina University

---

### ARTICLE INFO

#### *Article history:*

Received Nopember 12, 2020

Revised December 01, 2020

Accepted December 14, 2020

#### *Keywords:*

Automatic Door, Temperature  
Sensor MLX90614

### ABSTRACT

In today's very rapid technological developments, many tools or products are produced that can help humans in every activity they carry out. The application of technology that can facilitate human activities, for example, such as automatic doors. Where everyone who approaches the door, the door will open automatically because the human body temperature is detected. This electronic device that detects body temperature uses the MLX90614 temperature sensor. This tool can work with a distance of about 2 cm. With automatic doors using a temperature sensor, this can be applied to every door of a room with high mobility such as hotel and mall lobby doors.

*This is an open access article under the CC BY-NC license.*



---

#### *Corresponding Author:*

Tri Isra Janwardi,  
Electrical Engineering, Efarina University,  
Griya Hapoltakan Kav. 1-10, Jalan Sutomo, Pematang Raya,  
Bahapal Raya, Kec. Raya, Simalungun Regency, North Sumatra 21162.  
Email: [triisrajanwardi@gmail.com](mailto:triisrajanwardi@gmail.com)

---

## 1. INTRODUCTION

In the current era, there are still many places, especially places that have high mobility, which still use manual door openings. This manual process of opening and closing doors will certainly be ineffective if the place has large doors, for example in mall lobbies and hotel lobbies. This manual process of opening and closing doors will also make it difficult for humans who carry a number of groceries and of course those who have disabilities such as blind people when they enter public places such as minimarkets and others. unfamiliar, for example, to open and close a large door if done manually it will take a lot of time and effort. In this case, a tool will be made that can be used so that the door can open and close itself automatically. The problem that arises at the door is that when you want to enter, it is sometimes difficult to open. Even though sometimes the visitors are very many, it is necessary to make a device that can open and close the door automatically, with the help of information technology, it is able to control a series of electronic devices using Arduino by using sensors. The tool is a series of electronic components in the form of a door that can shift automatically which is controlled using a microcontroller program. This is one of the conveniences provided by automated technology in carrying out its work.

### A. Arduino

Arduino uno is a microcontroller based on Atmega328. Microcontroller is a circuit that works as a controller of an electronic circuit. This microcontroller controls the work processes that exist in the electronic circuit so that it can be adjusted as needed. The Arduino UNO has 14 digital input/output pins (6 of which can be used as PWM outputs), 6 analog inputs, a 16 MHz Crystal oscillator, a USB connection, a power jack, an ICSP header, and a reset button. Arduino UNO contains everything needed to support a

microcontroller, easily connects to a computer with a USB cable. Arduino uno board as shown in the following picture:

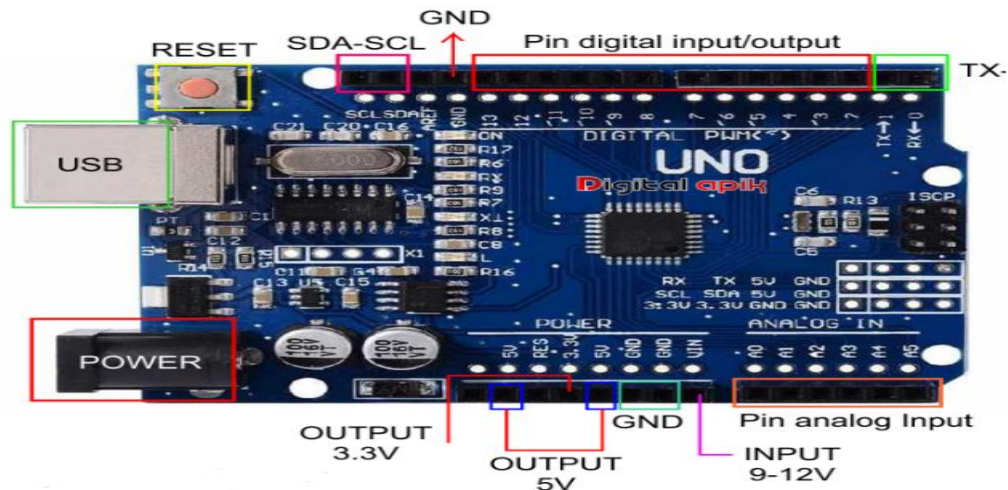

Figure 1. Arduino UNO

The configuration of the Arduino Uno section is as described below.

1. Digital input/output pins (0-13 . label)  
In general, these I / O pins are digital pins, namely pins that work at digital voltage levels (0V to 5V) for either input or output. 3,5,6,9,10 and 11, in addition to pins 0 and 1 also have a special function as serial communication pins.
2. Analog input pins (labels A0 – A5)  
These pins can accept analog input voltages between 0V to 5V, this voltage will be represented as a number 0 - 1023 in the program.
3. Pins for voltage sources This group of pins is a collection of pins related to the power source, for example 5V output, 3.3V output, GND (2 pins) and Vref (reference voltage for internal ADC readings)
4. IC ATmega328 S  
This IC acts as a data processing control center.
5. IC ATmega16U  
This IC is programmed to handle data communication with PC via USB port.
6. USB jack  
Is a USB type B socket as a serial data connection with a PC.
7. Jack Power  
Is a socket for external power supply between 9V and 12V DC.
8. ICSP (In-Circuit Serial Programming) port  
This port is used to program Arduino without bootloader.
9. Reset Button  
Used to reset the Arduino microcontroller board to start the program from scratch.

## B. Sensor MLX90614

Sensor MLX90614 which is a *contactless temperature sensor* (touchless). This means that to measure the temperature of an object, the sensor does not need to be in direct contact with the object. Simply point the sensor at the object you want to measure temperature. This sensor works by absorbing infrared light emitted by an object. Since this sensor is not in physical contact with the object being measured, it has a wide measurement range from  $-70^{\circ}\text{C}$  to  $+380^{\circ}\text{C}$ . Infrared radiation is a part of the electromagnetic spectrum which has a wavelength from 0.7 to 1000 microns. However, only 0.7 – 14 microns can be used to measure temperature. Because the intensity of infrared energy emitted by an object will be directly proportional to its temperature. So using a sophisticated optical system and detector, a sensor can be designed that can sense

infrared radiation only with a wavelength in the range of 0.7 - 14 microns as applied to many contactless thermometer products.

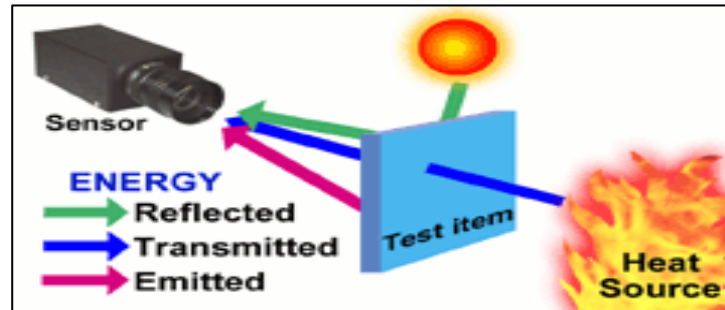

Figure 2. The working principle of the sensor

The photosensitive detector contained in the sensor will convert infrared energy into an electrical signal that is directly proportional to the temperature of the object that emits it. On the Sensor MLX 90614 the issued data can be read via the I2C/TWI protocol. Image Sensor MLX90614 is shown as in the image below.



Figure 3. Sensor MLX90614

### C. Servo Motor

Servo motor is an electromechanical device designed to use a closed loop type control system (servo) as a driver in a circuit that produces torque and speed based on electric current and applied voltage. These motors are applied to a wide range of equipment, from the simplest such as electronic toys to the complex ones such as industrial machines. Servo motors are types of electric motors that use a closed loop type system. This system is used to control the speed and acceleration of electric motors using a fairly high level of accuracy. In addition, these motors are commonly used to convert electrical energy into mechanical energy by the interaction of two permanent magnetic fields. The motor can also be defined as a rotary actuator or similarly called a motor, which is designed using a closed loop type control system (servo). Thus, it can be set to determine and confirm the angular position of the output shaft. The image of the severti motro servo is shown in the following figure.

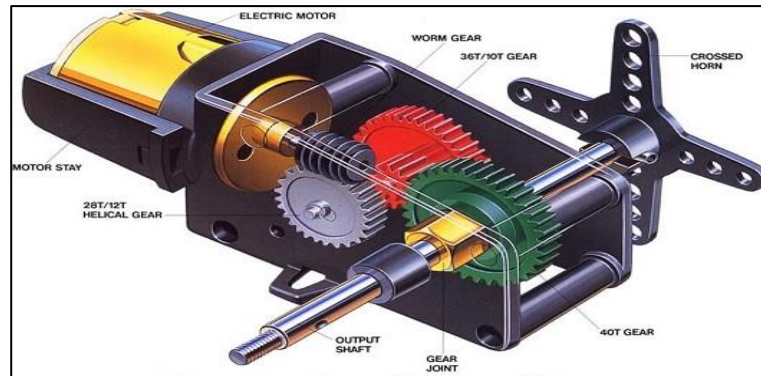

Figure 4. Servo motor construction

#### D. LCD

LCD or *Liquid Crystal Display* is a type of display media that uses liquid crystals to produce a visible image .

LCD or Liquid Crystal Display parts include :

- Polarized Layer 1 (Polarizing Film 1)
- Positive Electrode
- Liquid Crystal Layer
- Negative Electrode
- Polarized Layer 2 (Polarizing film 2)
- Backlight or Mirror (Backlight or Mirror)

The working principle of the LCD is that it emits light such as: white light is light consisting of hundreds of different colored lights. Hundreds of colors of light will be seen when white light reflects or changes the direction of the light. That is, if the angle of reflection differs , the color of the light produced will be different. The white LCD backlight will provide lighting on the Liquid Crystal or Liquid Crystal. The liquid crystal will filter the backlight it receives and reflect it at the desired angle so as to produce the required color. Liquid Crystal Angle will change when given a voltage with a certain value. Because by changing the angle and filtering the backlight on the liquid crystal , the backlight that was previously white can change into various colors. If you want to produce white color, then the liquid crystal will be opened as wide as possible so that the white backlight can be fully displayed. On the other hand, if you want to display black, the liquid crystal must be tightly closed so that no backlight can penetrate. And if you want other colors, it is necessary to adjust the reflection angle of the liquid crystal in question. The LCD is used as in the picture below.

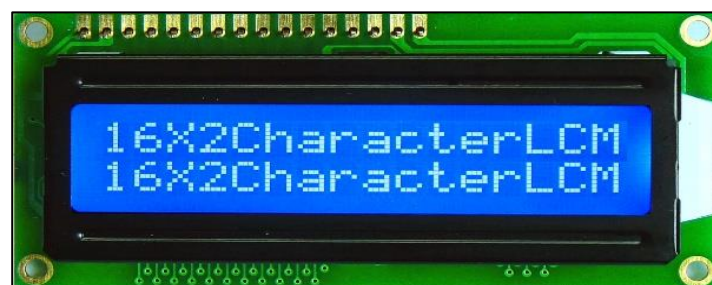

Figure 4. LCD

## 2. RESEARCH METHOD

Based on the study to be studied, the *flowchart* of this research is as shown in the following figure.

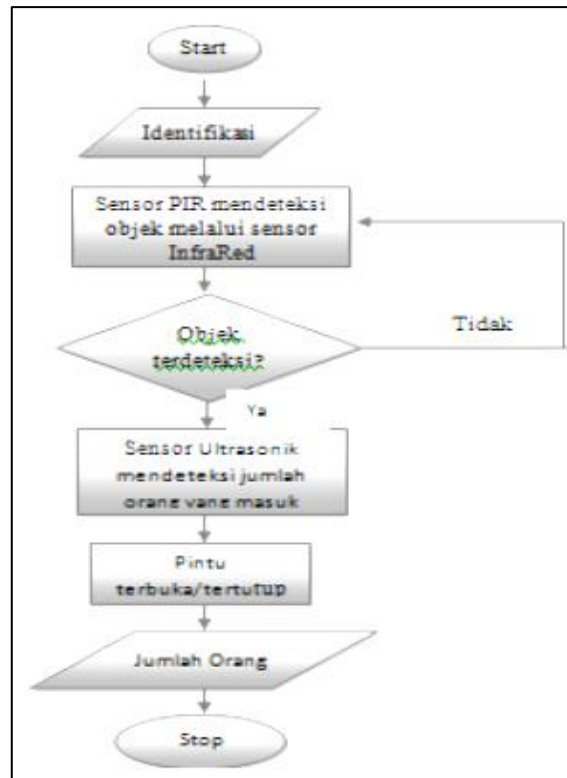

Figure 5. Research *flowchart*

## 3. RESULTS AND DISCUSSIONS

### A. One-line circuit diagram

The wiring diagram of the automatic door using the MLX90614 sensor is shown in the image below.

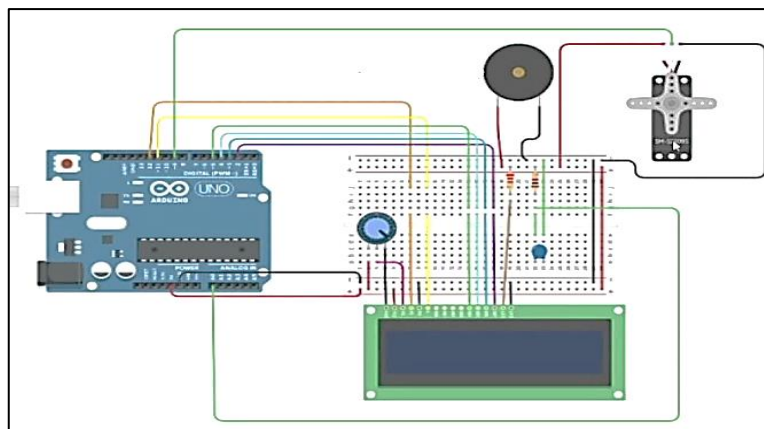

Figure 6. One line circuit diagram

Then from the measurement results of this automatic door prototype, several tests were carried out as follows. The response of the MLX90614 temperature sensor to the detected distance readings is as shown in the following table.

Table 1. Sensor reading results

No	Distance	Sensor Results MLX90614
1	1 cm	Can be detected
2	2 cm	Can be detected
3	3 cm	Cannot be detected

From the measurement results it was found that the sensor can work a maximum of 2 cm from the object. So that if detected, it will command the servo motor to open the door automatically.

#### 4. CONCLUSION

This study discusses the design of automatic doors based on body temperature. The results of this study can be concluded as follows:

1. At a distance of 1 cm the sensor can detect body temperature so that it can command the servo motor to open the door.
2. At a distance of 2 cm the sensor can detect body temperature so that it can command the servo motor to open the door.
3. At a distance of 3 cm the sensor cannot detect body temperature so it cannot command the servo motor to open the door

#### ACKNOWLEDGEMENTS

Thank you to everyone who was involved in writing this article

#### REFERENCES

- Zulkarnain S, Olivia F. P Sereng. 2010. "Microcontroller-Based Automatic Doors Using RFID". Makassar: Ujung Pandang State Polytechnic.
- Iswandii, Daud., Triayudi, Agung., Handayani, Endah Tri Esti. May 2020. Electronic Alarm Uses Arduino with Ultrasonic Sensor and MP3 Module as ther School Bell Time at Kemala Bhayangkari Delog Vocational School.
- Lestari, Novi. December 2017. Rangan Builds Automatic Doors Using Arduino Uno and PIR (Passive Infra Red) Sensors at SMP Negeri Simpang Semambang. *Jusikom: Journal of Musirawas Computer Systems*.