

Application of Roboduino ATmega 2560 in the Making of the Fire Extinguisher Beetle Robot

Saut Situmorang

Electrical Engineering, Efarina University

ARTICLE INFO

Article history:

Received November 15, 2020

Revised November 26, 2020

Accepted December 22, 2020

Keywords:

Arduino ATmega 2560, fire extinguisher

ABSTRACT

Rapid technological advances, especially in technology such as robots, provide a lot of help for humans in tasks that are difficult for humans to do. As in the case of fire disasters that often occur, it has caused many casualties and property losses. When the fire is extinguished, there is a risk that must be borne by the firefighting team when extinguishing the fire inside something. Risks that can occur, such as being hit by objects falling from the roof of a building or fires that are getting worse grow up. In this study, a prototype fire fighting beetle robot will be made where the simulation is carried out by making a fire in an area. Implementation is done by controlling the robot with applications that include the ability to move, detect hotspots and extinguish fires. Prototype of Fire Detection using Infrared Flame Sensor Based on Arduino Atmega 2560 consists of 3 main blocks, namely: Infrared Flame Sensor, Notification, and Fire Extinguisher. This prototype was made so that later it can be realized so that it can help the firefighters in the event of a fire, especially in areas that are difficult to reach by fire engines.

This is an open access article under the CC BY-NC license.



Corresponding Author:

Saut Situmorang,
Electrical Engineering, Efarina University,
Griya Hapoltakan Kav. 1-10, Jalan Sutomo, Pematang Raya,
Bahapal Raya, Kec. Raya, Simalungun Regency, North Sumatra 21162.
Email: sautsitumorang@gmail.com

1. INTRODUCTION

In the development of increasingly advanced science and technology, many are used to meet human needs. This rapid technological development is marked by the number of equipment that has been created and operated both manually and automatically. One of the technological developments is robots, robots have been developed to be able to assist humans in doing work that is complex, dangerous and requires precision. Such work, for example, extinguishing a fire in a building whose structure is unstable so that it can collapse at any time, by using robots, the work can be carried out without threatening the lives of firefighters. Fire fighting robots require various sensors to carry out their functions properly, including fire detection sensors and ultrasonic sensors to detect obstacles and then provide information to the microcontroller so that the robot will avoid obstacles. The fire fighting robot will also be equipped with a fire sensor and fan as a complementary performance device to extinguish the fire, the fan turns on automatically if the fire sensor approaches the fire point, in the fire point test using a candle with a height that is adjusted to the robot. User commands from the smartphone are sent to the microcontroller on the robot to be processed into robot movement. With this background, the author makes a Roboduino Atmega 2560 application in the manufacture of the Fire Extinguisher Beetle Robot.

A. Arduino ATmega 2560

Arduino ATmega 2560 is a microcontroller board based on ATmega 2560. Arduino ATmega 2560 has 54 digital input/ output pins, of which 15 pins can be used as PWM outputs, 16 pins as analog inputs, and 4 pins as UART (hardware serial port), 16 MHz crystal oscillator, USB connection, power jack, ICSP header, and reset button. This is all that is needed to support the microcontroller. Simply connect it to a computer via a USB cable or power it with an AC-DC adapter or battery to start activating it. Arduino ATmega 2560 is compatible with most shields designed for Arduino Duemilanove or Arduino Diecimila. Arduino ATmega 2560 is the latest version that replaces the Arduino ATmega version. The Arduino ATmega 2560 differs from the previous board, in that the latest version does not use the FTDI USB-to-serial driver chip. However, it uses the ATmega 16U2 chip (ATmega 8U2 on the Revision 1 and Revision 2) boards programmed as a USB-to-serial converter. The Arduino ATmega 2560 Revision 2 has an 8U2 HWB line pull resistor to Ground, making it easier to put into DFU mode. 16 Arduino ATmega 2560 Revision 3 has the following new features:

1. Pinout added the sda pin and scl pin which is close to the aref pin and the other two new pins are placed close to the reset pin, the ioref allows the shield to adapt to the available voltage on the board.
2. Reset circuit The reset circuit is a reprogramming setting path. where this feature can be used when there is a programming error. or want to change the program.
3. The ATmega 16U2 chip replaces the ATmega 8U2 chip using the ATmega 16U2 chip (ATmega 8U2 on Revision 1 and Revision 2) boards programmed as a USB-to-serial converter. Arduino ATmega 2560 Revision 2 has an 8U2 HWB line pull resistor to Ground, making it easier to put into DFU mode



Figure 1. Arduino ATmega 2560 . construction

B. Ultrasonic sensor

The PING sensor is an ultrasonic sensor that can detect the distance of an object by emitting ultrasonic waves with a frequency of 40 KHz and then detecting its reflection. This sensor can measure distances from 3 cm to 300 cm. The output of this sensor is a pulse whose width represents the distance. The pulse width varies from 115 μ s to 18.5 ms. Basically, Ping consists of a 40KHz signal generator chip, an ultrasonic speaker and an ultrasonic microphone. The ultrasonic speaker converts the 40 KHz signal into sound while the ultrasonic microphone detects the reflection of the sound. The signal pin can be directly connected to the microcontroller without any additional components. Ping will only send ultrasonic sound when there is a trigger pulse from the microcontroller (high pulse for 5 μ s). Ultrasonic sound with a frequency of 40KHz will be emitted for 200 μ s. This sound will travel through the air at a speed of 344,424m/s (or 1cm every 29,034 μ s), hitting an object and then bouncing back to Ping.



Figure 2. Ping sensor

C. DC Motor

An electric motor is an electromagnetic device that converts electrical energy into mechanical energy. This mechanical energy is used to, for example, rotate the pump *impeller*, *fan* or *blower*, move the compressor, lift materials, etc. Electric motors are also used at home (*mixers*, electric drills, wind *fans*) and in industry. Electric motors are sometimes called the "work horse" of industry because it is estimated that they use about 70% of the industry's total electrical load. DC motors require a direct voltage supply to the field coil to be converted into mechanical energy. The field coil in a dc motor is called the stator (the non-rotating part) and the armature coil is called the rotor (the rotating part). If there is a rotation of the inner armature coil in a magnetic field, there will be a voltage (emf) that changes direction in every half turn, so it is an alternating voltage.



Figure 3. DC Motor (Dynamo)

D. Servo Motor

Servo motor is an electromechanical device designed to use a closed loop type control system (servo) as a driver in a circuit that produces torque and speed based on electric current and applied voltage. These motors are applied to a wide range of equipment, from the simplest such as electronic toys to the complex ones such as industrial machines. Servo motors are types of electric motors that use a closed loop type system. This system is used to control the speed and acceleration of electric motors using a fairly high level of accuracy. In addition, these motors are commonly used to convert electrical energy into mechanical energy by the interaction of two permanent magnetic fields. The motor can also be defined as a rotary actuator or similarly called a motor, which is designed using a closed loop type control system (servo). Thus,

it can be set to determine and confirm the angular position of the output shaft. The image of the severti motro servo is shown in the following figure.



Figure 4. Servo motor

E. Light Sensor

light sensor is a diode that works based on light intensity , if the photodiode is exposed to light then the photodiode works like a diode in general, but if it does not get light, the photodiode will act like a resistor with a large resistance value so that electric current cannot flow. photodiode is a semiconductor light sensor that can convert light into electrical quantities.

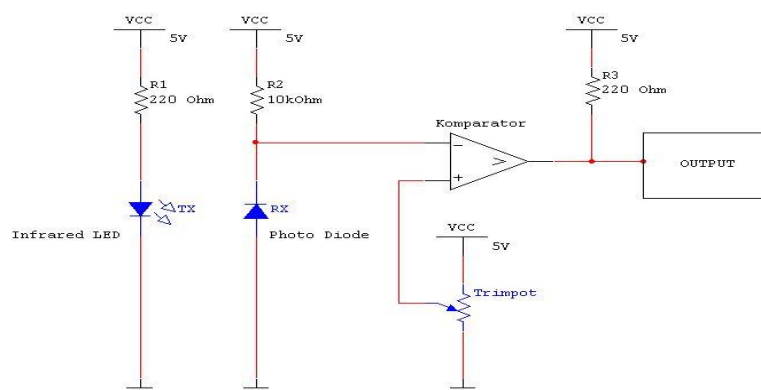

Figure 5. Photodiode circuit

2. RESEARCH METHOD

. Based on the study to be researched, namely the application of the Roboduino Atmega 2560 in the manufacture of the Fire Extinguishing Beetle Robot. *The flowchart of this* research is as shown in the following figure.

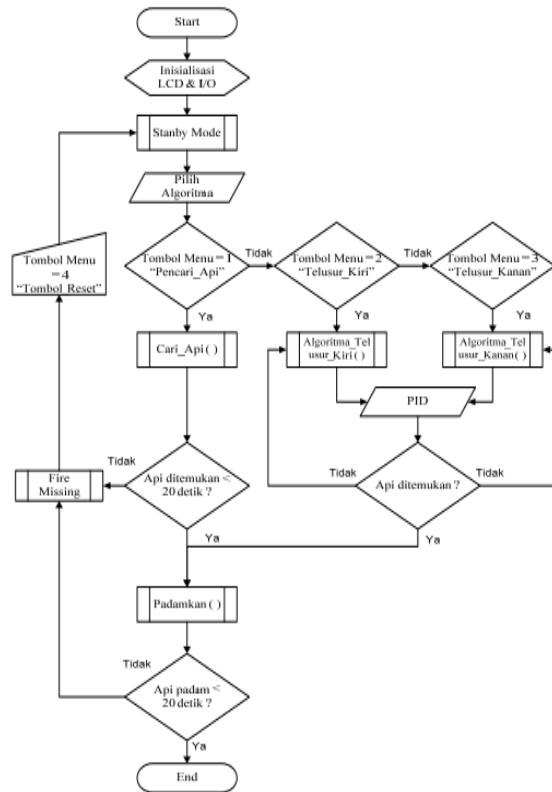

Figure 6. Research flowchart

3. RESULTS AND DISCUSSIONS

A. Set of tools

The series of tools as shown in the image below.

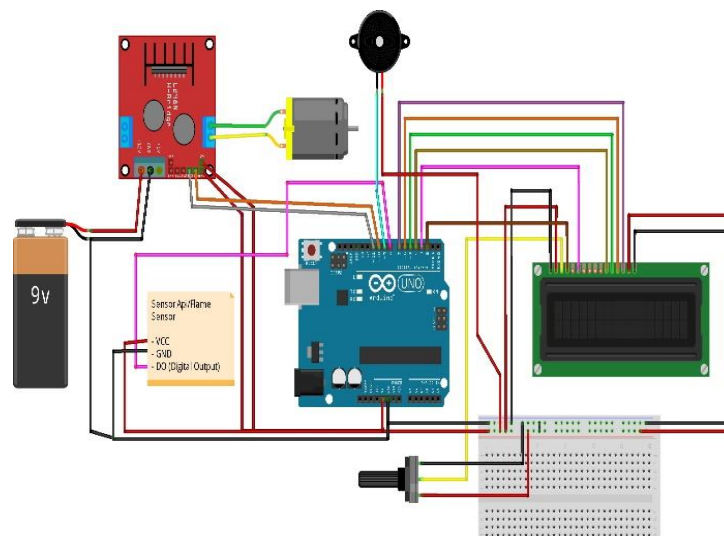

Figure 7. Servo motor

B. Distance test results

fire distance test with the robot are as shown in the table below.

Table 1. Results of testing the distance of the robot to the fire source

Distance (cm)	Response
10	Can Respond
20	Can Respond
30	Can Respond
40	Can't Respond

C. Fire Sensor test results

fire sensor test with the fire source are shown in the table below.

Table 2. Fire Sensor Test Results

Status	Response
There's a Barrier	Can't Respond
No barrier	Can Respond
Maximum Distance	30 cm

4. CONCLUSION

This study discusses the application of Roboduino Atmega 2560 in the manufacture of fire fighting beetle robots . The results of this study can be concluded as follows:

1. The maximum distance that the proximity sensor and fire sensor can detect is 30 cm
2. If there is an obstacle, the fire sensor cannot detect the source of the fire
3. If there is no barrier then the sensor can detect the source of the fire

ACKNOWLEDGEMENTS

Thank you to everyone who was involved in writing this article

REFERENCES

- Budiharto, W. & Purwanto, D. 2015. *Robot Vision, Robot Building Techniques Smart Future* . Revised Edition. Andi: Jakarta
- Indriyanto, Cholik. 2015. *Design of Remote Control Robot Control System Car Using Android Smartphone* . Researchgate: University of North Sumatra.
- Fatmawati. 27 Oktober 2013. Ultrasonic sensor. electronicadasar.info/sensorultrasonic.htm
- irawan. 2012. *Creating Android Applications for the Common People*. Maxikom : Palembang.